

IGCSE MATHEMATICS 4400
FORMULA SHEET – HIGHER TIER

Pythagoras' Theorem

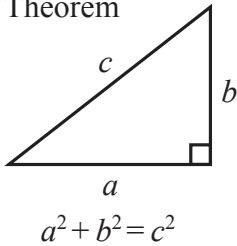

Volume of cone = $\frac{1}{3} \pi r^2 h$

Curved surface area of cone = $\pi r l$

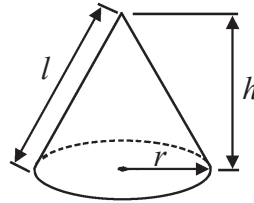

Volume of sphere = $\frac{4}{3} \pi r^3$

Surface area of sphere = $4\pi r^2$

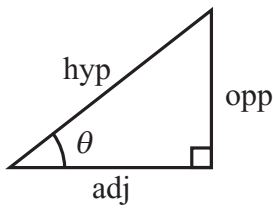
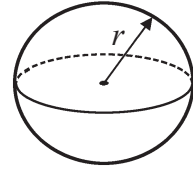

adj = hyp \times cos θ
opp = hyp \times sin θ
opp = adj \times tan θ

or $\sin \theta = \frac{\text{opp}}{\text{hyp}}$

$\cos \theta = \frac{\text{adj}}{\text{hyp}}$

$\tan \theta = \frac{\text{opp}}{\text{adj}}$

In any triangle ABC

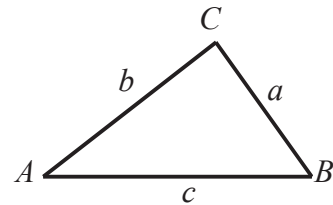

Sine rule: $\frac{a}{\sin A} = \frac{b}{\sin B} = \frac{c}{\sin C}$

Cosine rule: $a^2 = b^2 + c^2 - 2bc \cos A$

Area of triangle = $\frac{1}{2} ab \sin C$

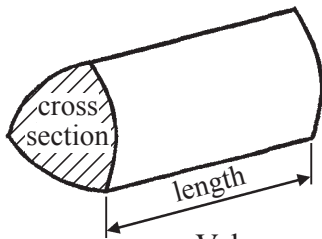

Volume of prism = area of cross section \times length

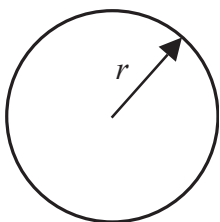

Circumference of circle = $2\pi r$

Area of circle = πr^2

Area of a trapezium = $\frac{1}{2} (a + b)h$

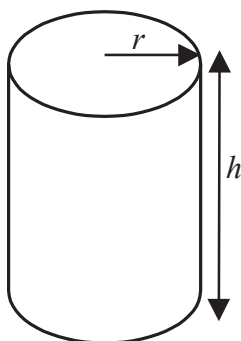
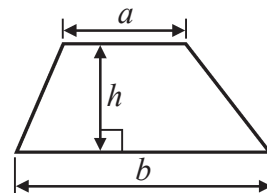

Volume of cylinder = $\pi r^2 h$

Curved surface area of cylinder = $2\pi r h$

The Quadratic Equation

The solutions of $ax^2 + bx + c = 0$, where $a \neq 0$, are given by

$$x = \frac{-b \pm \sqrt{b^2 - 4ac}}{2a}$$



Answer ALL TWENTY ONE questions.

Write your answers in the spaces provided.

You must write down all the stages in your working.

1. The diagram shows the lengths, in cm, of the sides of a triangle.

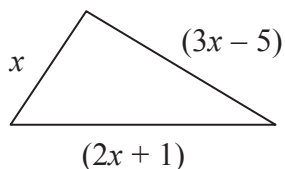

The perimeter of the triangle is 17 cm.

- (i) Use this information to write an equation in x .

.....

- (ii) Solve your equation.

$x =$

Q1

(Total 3 marks)

2. Anji mixes sand and cement in the ratio 7 : 2 by weight.
The total weight of the mixture is 27 kg.

Calculate the weight of sand in the mixture.

..... kg

Q2

(Total 3 marks)



3. Solve $5(x - 4) = 35$

$x = \dots\dots\dots$

(Total 3 marks)

Q3

4. Julian has to work out $\frac{6.8 \times 47.6}{2.09}$ without using a calculator.

(a) Round each number in Julian's calculation to one significant figure.

$\dots\dots\dots$
(2)

(b) Use your rounded numbers to work out an estimate for $\frac{6.8 \times 47.6}{2.09}$

Give your answer correct to one significant figure.

$\dots\dots\dots$
(2)

(c) Without using your calculator, explain why your answer to part (b) should be larger than the exact answer.

$\dots\dots\dots$
 $\dots\dots\dots$
 $\dots\dots\dots$

(2)

(Total 6 marks)

Q4



5. The diagram shows a wall.

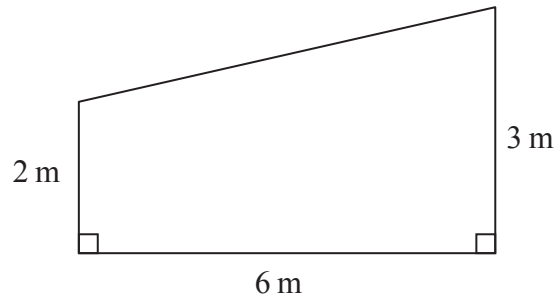

Diagram **NOT** accurately drawn

(a) Calculate the area of the wall.

..... m²
(2)

(b) 1 litre of paint covers an area of 20 m².
Work out the volume of paint needed to cover the wall.
Give your answer in cm³.

..... cm³
(3)

(Total 5 marks)

Q5



6. Solve the simultaneous equations

$$y = x + 3$$
$$y = 7x$$

$x = \dots\dots\dots$

$y = \dots\dots\dots$

(Total 3 marks)

Q6



7. (a)

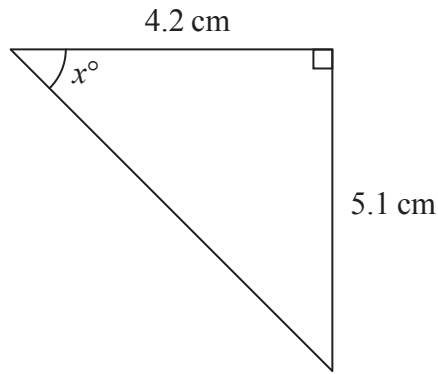

Diagram **NOT** accurately drawn

Calculate the value of x .
Give your answer correct to 3 significant figures.

$x = \dots\dots\dots$
(3)

(b)

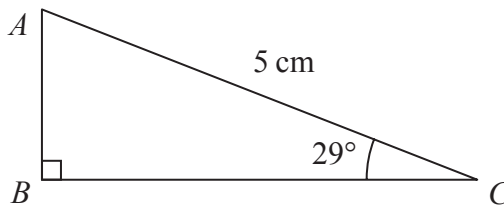

Diagram **NOT** accurately drawn

Calculate the length of AB .
Give your answer correct to 3 significant figures.

$\dots\dots\dots$ cm
(3)

(Total 6 marks)

Q7



8. A bag contains some marbles.
The colour of each marble is red or blue or green or yellow.

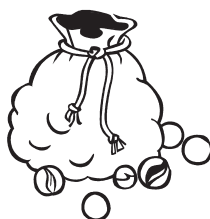

A marble is taken at random from the bag.
The table shows the probability that the marble is red or blue or green.

Colour	Probability
Red	0.1
Blue	0.2
Green	0.1
Yellow	

- (a) Work out the probability that the marble is yellow.

.....
(2)

- (b) Work out the probability that the marble is blue or green.

.....
(2)

The probability that the marble is made of glass is 0.8

- (c) Beryl says “The probability that the marble is green or made of glass is $0.1 + 0.8 = 0.9$ ”

Is Beryl correct?

Give a reason for your answer.

.....
.....
(2)

(Total 6 marks)

Q8



9.

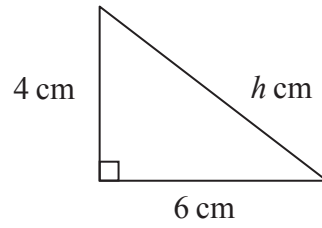

Diagram **NOT** accurately drawn

Calculate the value of h .
Give your answer correct to 3 significant figures.

$h = \dots\dots\dots$

(Total 3 marks)

Q9

PLEASE TURN OVER FOR QUESTION 10



10. (a)

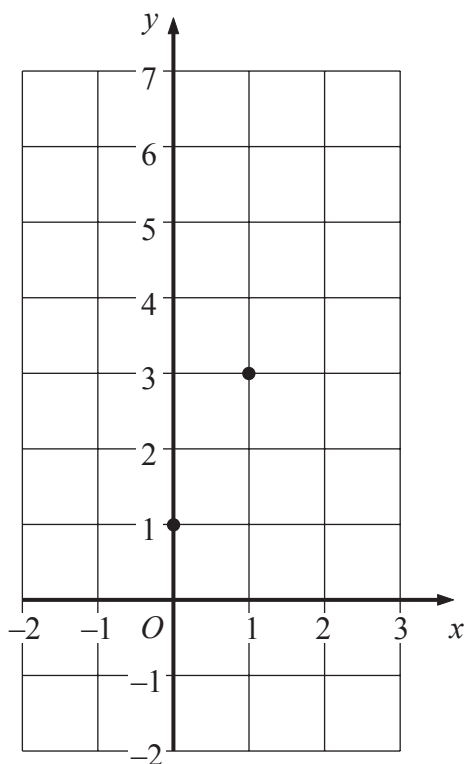

Find the equation of the straight line that passes through the points (0, 1) and (1, 3).

.....
(4)

(b) Write down the equation of a line parallel to the line whose equation is $y = -2x + 5$

.....
(1)

(c) Write down the coordinates of the point of intersection of the two lines whose equations are $y = 3x - 4$ and $y = -2x - 4$

(.....,)
(1)

(Total 6 marks)

Q10



11. Here are three similar triangles.

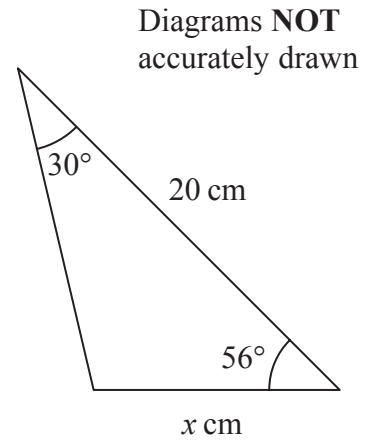
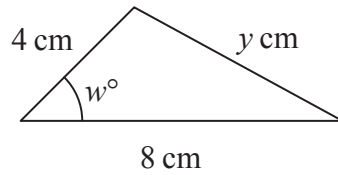
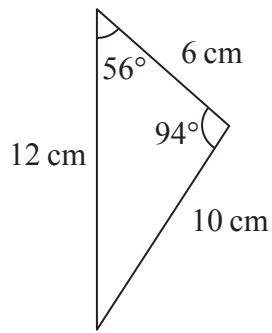

Find the value of

(a) w ,

$w = \dots\dots\dots$ **(1)**

(b) x ,

$x = \dots\dots\dots$ **(2)**

(c) y .

$y = \dots\dots\dots$ **(2)**

(Total 5 marks)

Q11



12. Simplify

(a) $\frac{a^3 \times a^4}{a^2}$

.....
(2)

(b) $(\sqrt{x})^6$

.....
(1)

(c) $\frac{3(x+1)^2}{6(x+1)}$

.....
(2)

(Total 5 marks)

Q12



13. Here are the marks scored in a maths test by the students in two classes.

Class A 2 13 15 16 4 6 19 10 11 4 5 15 4 16 6

Class B 12 11 2 5 19 14 6 6 10 14 9

(a) Work out the interquartile range of the marks for each class.

Class A

Class B

(4)

(b) Use your answers to give one comparison between the marks of Class A and the marks of Class B.

.....

.....

(1)

(Total 5 marks)

Q13

14. Solve

$$\frac{5x-7}{x-1} = x+1$$

.....

(Total 4 marks)

Q14



15. There are 35 students in a group.
 18 students play hockey.
 12 students play both hockey and tennis.
 15 students play neither hockey nor tennis.

Find the number of students who play tennis.

..... Q15

 (Total 4 marks)

16. A triangle has sides of length 5 cm, 6 cm and 9 cm.

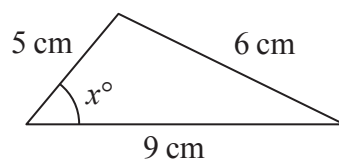

Diagram **NOT** accurately drawn

Calculate the value of x .
 Give your answer correct to 3 significant figures.

$x =$ Q16

 (Total 3 marks)



17. The functions f and g are defined as follows.

$$f(x) = \frac{1}{x+2}$$

$$g(x) = \sqrt{x-1}$$

(a) (i) State which value of x cannot be included in the domain of f .

.....

(ii) State which **values** of x cannot be included in the domain of g .

.....

(3)

(b) Calculate $fg(10)$

.....

(3)

(c) Express the inverse function g^{-1} in the form $g^{-1}(x) = \dots$

.....

(4)

(Total 10 marks)

Q17

--	--



18. A fair, 6-sided dice has faces numbered 1, 2, 3, 4, 5 and 6
When the dice is thrown, the number facing up is the score.
The dice is thrown three times.

(a) Calculate the probability that the total score is 18

.....
(2)

(b) Calculate the probability that the score on the third throw is exactly double the **total**
of the scores on the first **two** throws.

.....
(4)

(Total 6 marks)

Q18



19. (a) Calculate the area of an equilateral triangle of side 5 cm.
Give your answer correct to 3 significant figures.

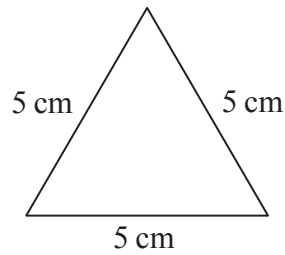

Diagram **NOT** accurately drawn

..... cm²
(2)

- (b) The diagram shows two overlapping circles.
The centre of each circle lies on the circumference of the other circle.
The radius of each circle is 5 cm.
The distance between the centres is 5 cm.

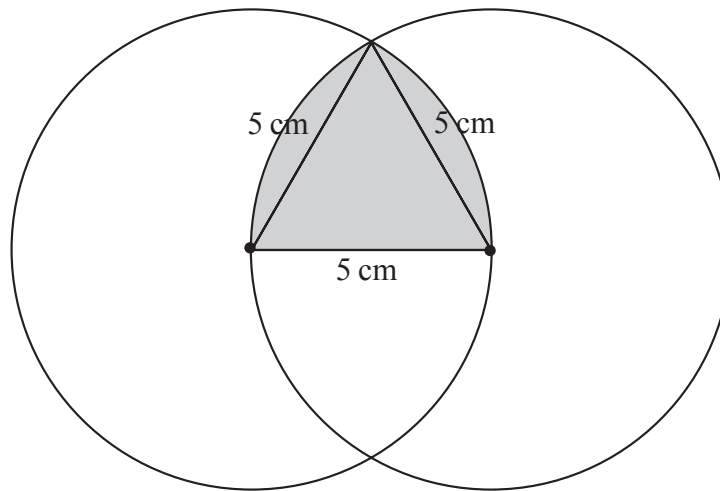

Diagram **NOT** accurately drawn

Calculate the area of the shaded region.
Give your answer correct to 3 significant figures.

..... cm²
(3)

(Total 5 marks)

Q19



20. The histogram shows information about the height, h metres, of some trees.

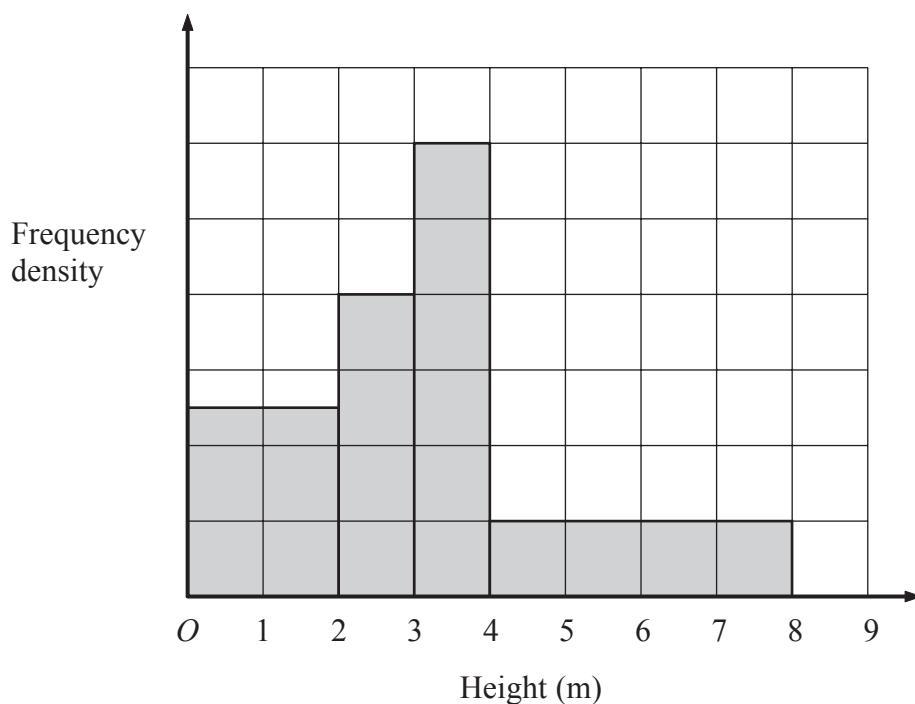

The number of trees with heights in the class $2 < h \leq 3$ is 20

Find the number of trees with heights in the class

(i) $4 < h \leq 8$

.....

(ii) $3 < h \leq 4$

.....

(Total 3 marks)

Q20



21. (a) Factorise $16x^2 - 1$

.....
(1)

(b) Hence express as the product of its prime factors

(i) 1599

.....

(ii) 1.599×10^6

.....
(5)

Q21

(Total 6 marks)

TOTAL FOR PAPER: 100 MARKS

END



BLANK PAGE

