

Centre No.					Surname	Initial(s)
Candidate No.					Signature	

Paper Reference(s)

4400/3H

Examiner's use only

--	--	--

London Examinations IGCSE

Team Leader's use only

--	--	--

Mathematics

Paper 3H

Higher Tier

Friday 5 May 2006 – Morning

Time: 2 hours

Page Numbers	Leave Blank
3	
4	
5	
6	
7	
8	
9	
10	
11	
12	
13	
14	
15	
16	
17	
18	
19	
Total	

Materials required for examination

Ruler graduated in centimetres and millimetres, protractor, compasses, pen, HB pencil, eraser, calculator. Tracing paper may be used.

Items included with question papers

Nil

Instructions to Candidates

In the boxes above, write your centre number, candidate number, your surname, initial(s) and signature.

The paper reference is shown at the top of this page. Check that you have the correct question paper. Answer **ALL** the questions in the spaces provided in this question paper. Show all the steps in any calculations.

Information for Candidates

There are 20 pages in this question paper. All blank pages are indicated.

The total mark for this paper is 100. The marks for parts of questions are shown in round brackets: e.g. (2).

You may use a calculator.

Advice to Candidates

Write your answers neatly and in good English.

This publication may be reproduced only in accordance with Edexcel Limited copyright policy. ©2006 Edexcel Limited.

Printer's Log. No.
N24646A

W850/R4400/57570 4/3/3/4600



N 2 4 6 4 6 A 0 1 2 0

Turn over

edexcel INTERNATIONAL

**IGCSE MATHEMATICS 4400
FORMULA SHEET – HIGHER TIER**

Pythagoras' Theorem

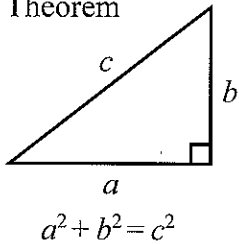

Volume of cone = $\frac{1}{3} \pi r^2 h$

Curved surface area of cone = $\pi r l$

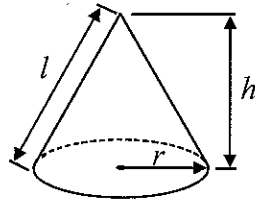

Volume of sphere = $\frac{4}{3} \pi r^3$

Surface area of sphere = $4 \pi r^2$

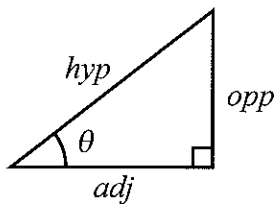
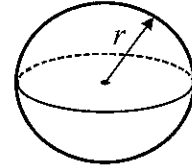

adj = hyp \times cos θ
opp = hyp \times sin θ
opp = adj \times tan θ

or $\sin \theta = \frac{\text{opp}}{\text{hyp}}$

$\cos \theta = \frac{\text{adj}}{\text{hyp}}$

$\tan \theta = \frac{\text{opp}}{\text{adj}}$

In any triangle ABC

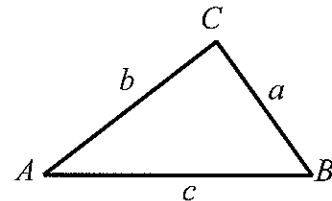

Sine rule $\frac{a}{\sin A} = \frac{b}{\sin B} = \frac{c}{\sin C}$

Cosine rule $a^2 = b^2 + c^2 - 2bc \cos A$

Area of triangle = $\frac{1}{2} ab \sin C$

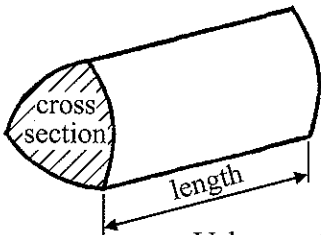

Volume of prism = area of cross section \times length

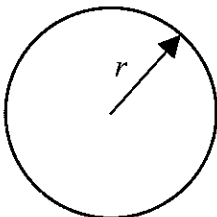

Circumference of circle = $2 \pi r$

Area of circle = πr^2

Area of a trapezium = $\frac{1}{2} (a + b) h$

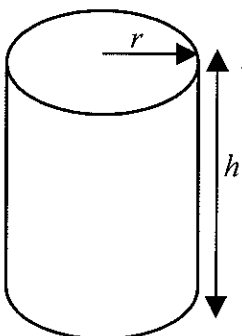
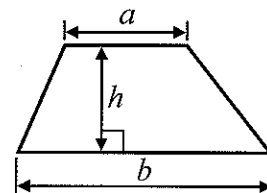

Volume of cylinder = $\pi r^2 h$

Curved surface area of cylinder = $2 \pi r h$

The Quadratic Equation

The solutions of $ax^2 + bx + c = 0$ where $a \neq 0$, are given by

$$x = \frac{-b \pm \sqrt{b^2 - 4ac}}{2a}$$



Answer ALL TWENTY-THREE questions.

Write your answers in the spaces provided.

You must write down all stages in your working.

1. The surface area of the Earth is 510 million km².
The surface area of the Pacific Ocean is 180 million km².

- (a) Express 180 million as a percentage of 510 million.
Give your answer correct to 2 significant figures.

.....%
(2)

The surface area of the Arctic Ocean is 14 million km².
The surface area of the Southern Ocean is 35 million km².

- (b) Find the ratio of the surface area of the Arctic Ocean to the surface area of the Southern Ocean.
Give your ratio in the form 1 : *n*.

1 :
(2)

(Total 4 marks)

Q1

2. Solve $7 - 4x = 10$

$x =$

(Total 3 marks)

Q2



3.

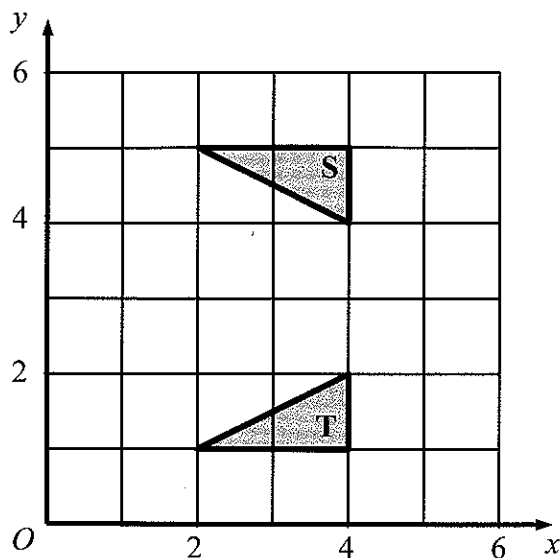

Describe fully the single transformation that maps triangle S onto triangle T.

.....

(Total 2 marks)

Q3

4. (a) Work out the value of $y^2 - 4y$ when $y = -3$

.....
(2)

(b) Simplify

(i) $p^3 \times p^5$

.....

(ii) $q^7 \div q$

.....
(2)

(Total 4 marks)

Q4



5. Robin fired 15 arrows at a target.
The table shows information about his scores.

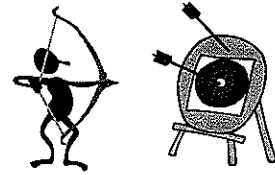

Score	Frequency
1	6
2	3
3	1
4	1
5	4

- (a) Find his median score.

.....
(2)

- (b) Work out his mean score.

.....
(3)

(Total 5 marks)

Q5



6. (a) Work out $\frac{2}{15} \times 6$

Give your answer as a fraction in its simplest form.

.....
(2)

(b) Work out $2\frac{2}{3} \div \frac{5}{6}$

Give your answer as a mixed number in its simplest form.

.....
(2)

(Total 4 marks)

Q6

7.

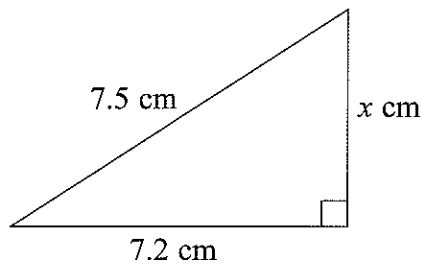

Diagram NOT accurately drawn

Work out the value of x .

$x =$

(Total 3 marks)

Q7



8. The perimeter of a triangle is 54 cm.
The lengths of its sides are in the ratios 2 : 3 : 4

Work out the length of the longest side of the triangle.

..... cm

Q8

(Total 2 marks)

9. Show, by shading on the grid, the region which satisfies these inequalities

$$1 \leq x \leq 3 \quad \text{and} \quad -4 \leq y \leq -2$$

Label your region **R**.

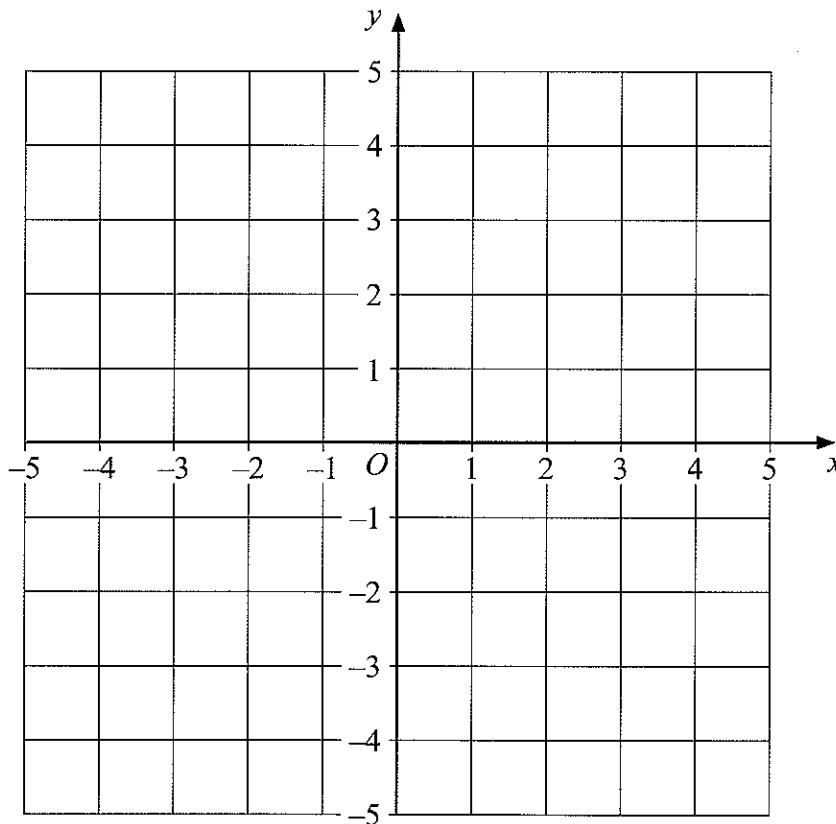

Q9

(Total 3 marks)



10.

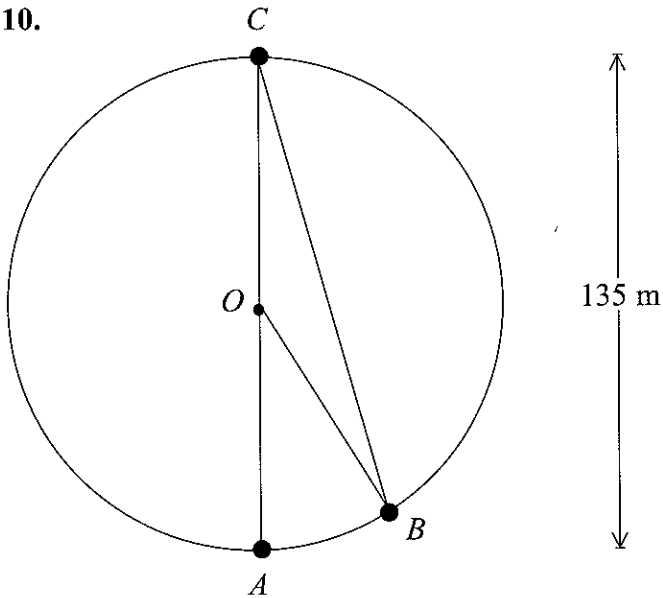
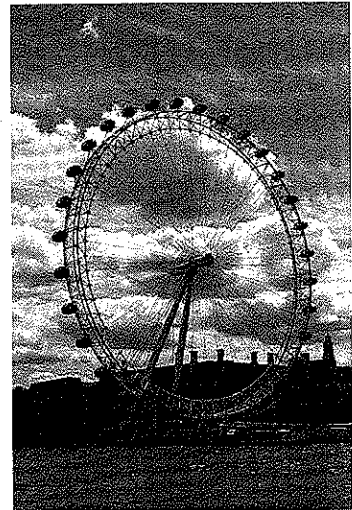

Diagram
NOT
accurately
drawn



The diagram represents part of the London Eye.
 A , B and C are points on a circle, centre O .
 A , B and C represent three capsules.
 The capsules at A and B are next to each other.
 A is at the bottom of the circle and C is at the top.

The London Eye has 32 equally spaced capsules on the circle.

(a) Show that angle $AOB = 11.25^\circ$.

(1)

(b) Find the size of the angle between BC and the horizontal.

.....
(3)



The capsules move in a circle of diameter 135 m.

- (c) Calculate the distance moved by a capsule in making a complete revolution. Give your answer correct to 3 significant figures.

..... m
(2)

The capsules move at an average speed of 0.26 m/s.

- (d) Calculate the time taken for a capsule to make a complete revolution. Give your answer in minutes, correct to the nearest minute.

..... min
(3)

Q10

(Total 9 marks)

11. Write as ordinary numbers

(i) 3.6×10^5

.....

(ii) 2.9×10^{-3}

.....

Q11

(Total 2 marks)



12.

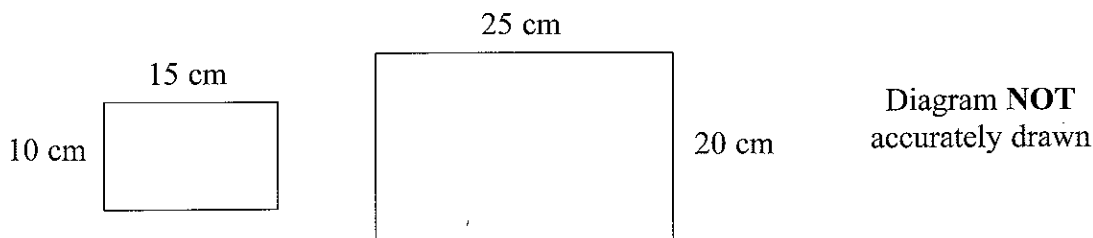

Are the two rectangles mathematically similar?
 Tick (✓) the appropriate box.
 You must show working to justify your answer.

Yes	No
<input type="checkbox"/>	<input type="checkbox"/>

Q12

(Total 3 marks)

13. (a) Expand and simplify $(3x - 5)(4x + 7)$

.....
(2)

(b) Simplify $(2p^4)^3$

.....
(2)

(c) Simplify $(64y^6)^{\frac{2}{3}}$

.....
(2)

Q13

(Total 6 marks)



14. Here is a biased spinner.

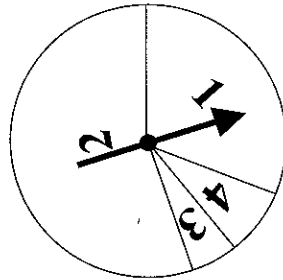

When the pointer is spun, the score is 1 or 2 or 3 or 4
 The probability that the score is 1 is 0.3
 The probability that the score is 2 is 0.6

Hajra spins the pointer once.

(a) Work out the probability that

(i) the score is 1 or 2

.....

(ii) the score is 3 or 4

.....

(3)

Nassim spins the pointer twice.

(b) Work out the probability that

(i) the score is 1 both times,

.....

(ii) the score is 2 exactly once.

.....

(5)

(Total 8 marks)

Q14



15. $\mathcal{E} = \{1, 2, 3, 4, 5, 6, 7, 8\}$
 $P = \{2, 3, 5, 7\}$

(a) List the members of P'

.....
 (1)

The set Q satisfies both the conditions $Q \subset P$ and $n(Q) = 3$

(b) List the members of **one** set Q which satisfies both these conditions.

.....
 (2)

(Total 3 marks)

Q15

16. Part of the graph of $y = x^2 - 2x - 4$ is shown on the grid.

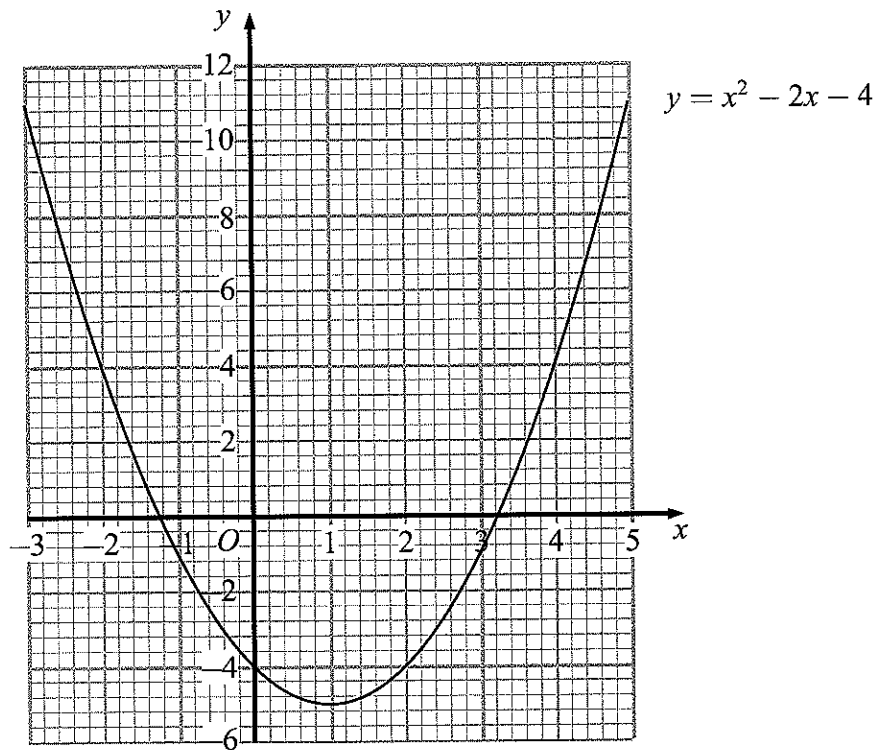

(a) Write down the coordinates of the minimum point of the curve.

(..... ,)
(1)

(b) Use the graph to find estimates of the solutions to the equation $x^2 - 2x - 4 = 0$
Give your answers correct to 1 decimal place.

.....
(2)

(c) Draw a suitable straight line on the grid to find estimates of the solutions of the equation $x^2 - 3x - 6 = 0$

.....
(3)

(d) For $y = x^2 - 2x - 4$

(i) find $\frac{dy}{dx}$,

.....

(ii) find the gradient of the curve at the point where $x = 6$

.....
(4)

(Total 10 marks)

Q16



17. Michael says "When the fraction $\frac{n}{45}$ is converted to a decimal, it never gives a terminating decimal."

(a) (i) Find a value of n which shows that Michael is wrong.

$n = \dots\dots\dots$

(ii) Write down the name of the type of number n must be, when $\frac{n}{45}$ gives a terminating decimal.

$\dots\dots\dots$
(2)

(b) $\frac{62}{45} < \sqrt{2} < \frac{64}{45}$

Use these bounds to write the value of $\sqrt{2}$ to an appropriate degree of accuracy. You must show your working and explain your answer.

$\dots\dots\dots$
(2)

(Total 4 marks)

Q17



18.

Diagram **NOT** accurately drawn

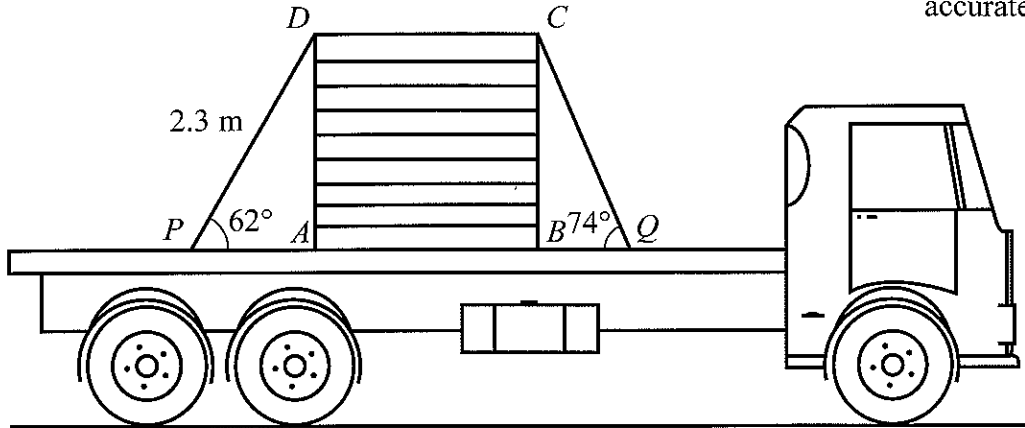

The diagram shows a side view of a rectangular box $ABCD$ on a lorry.
 The box is held down on the horizontal flat surface of the lorry by a rope.
 The rope passes over the box and is tied at two points, P and Q , on the flat surface.

- $DP = 2.3$ m.
- Angle $APD = 62^\circ$.
- Angle $BQC = 74^\circ$.

Calculate the length of BQ .
 Give your answer correct to 3 significant figures.

..... m

Q18

(Total 5 marks)



19. The unfinished table and histogram give information about the times taken by some students to complete a science test.

Time (t minutes)	Frequency
$0 < t \leq 30$	
$30 < t \leq 50$	70
$50 < t \leq 70$	85
$70 < t \leq 80$	
$80 < t \leq 90$	40

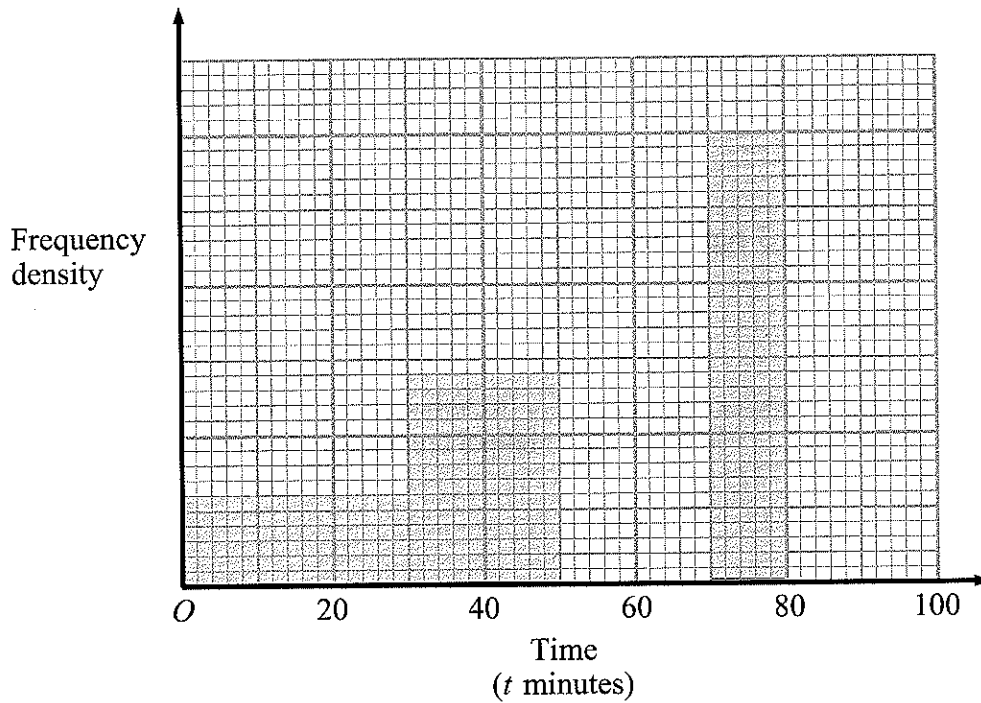

(a) Use the information in the table to complete the histogram. (2)

(b) Use the information in the histogram to complete the table. (2)

(Total 4 marks)

Q19



20. Make R the subject of the formula $A = \pi(R + r)(R - r)$

$R = \dots\dots\dots$

Q20

(Total 4 marks)

21. $(1 + 3\sqrt{5})^2 = p + q\sqrt{5}$ where p and q are integers.
Find the value of p and the value of q .

$p = \dots\dots\dots$

$q = \dots\dots\dots$

Q21

(Total 2 marks)



22.

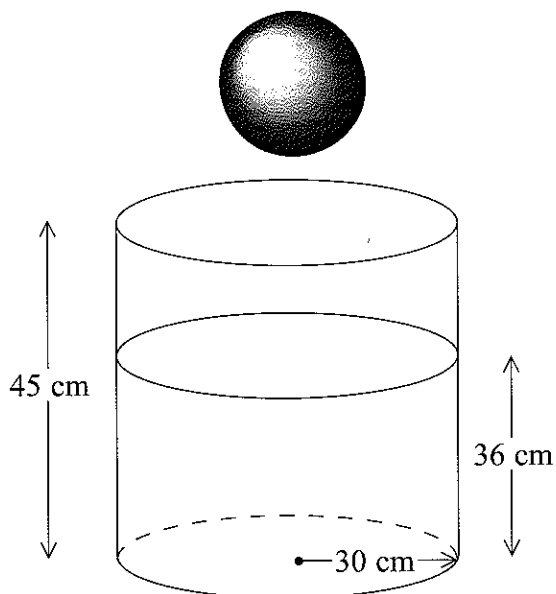

Diagram **NOT** accurately drawn

A cylindrical tank has a radius of 30 cm and a height of 45 cm.
The tank contains water to a depth of 36 cm.

A metal sphere is dropped into the water and is completely covered.
The water level rises by 5 cm.

Calculate the radius of the sphere.

..... cm

(Total 5 marks)

Q22



23.

$$f(x) = x^2$$

$$g(x) = 2x + 3$$

Solve $fg(x) = f(x)$.

Q23

.....
(Total 5 marks)**TOTAL FOR PAPER: 100 MARKS****END**

Edexcel gratefully acknowledges the following source used in the preparation of this paper.

- Photograph of London Eye: www.freefoto.com

