

Mark Scheme (Results)

Summer 2013

International GCSE Mathematics
(4MA0) Paper 4HR

Edexcel and BTEC Qualifications

Edexcel and BTEC qualifications come from Pearson, the world's leading learning company. We provide a wide range of qualifications including academic, vocational, occupational and specific programmes for employers. For further information, please visit our website at www.edexcel.com.

Our website subject pages hold useful resources, support material and live feeds from our subject advisors giving you access to a portal of information. If you have any subject specific questions about this specification that require the help of a subject specialist, you may find our Ask The Expert email service helpful.

www.edexcel.com/contactus

Pearson: helping people progress, everywhere

Our aim is to help everyone progress in their lives through education. We believe in every kind of learning, for all kinds of people, wherever they are in the world. We've been involved in education for over 150 years, and by working across 70 countries, in 100 languages, we have built an international reputation for our commitment to high standards and raising achievement through innovation in education. Find out more about how we can help you and your students at: www.pearson.com/uk

Summer 2013

Publications Code UG036369

All the material in this publication is copyright

© Pearson Education Ltd 2013

General Marking Guidance

- All candidates must receive the same treatment. Examiners must mark the first candidate in exactly the same way as they mark the last.
- Mark schemes should be applied positively. Candidates must be rewarded for what they have shown they can do rather than penalised for omissions.
- Examiners should mark according to the mark scheme not according to their perception of where the grade boundaries may lie.
- There is no ceiling on achievement. All marks on the mark scheme should be used appropriately.
- All the marks on the mark scheme are designed to be awarded. Examiners should always award full marks if deserved, i.e. if the answer matches the mark scheme.
- Examiners should also be prepared to award zero marks if the candidate's response is not worthy of credit according to the mark scheme.
- Where some judgement is required, mark schemes will provide the principles by which marks will be awarded and exemplification may be limited.
- When examiners are in doubt regarding the application of the mark scheme to a candidate's response, the team leader must be consulted.
- Crossed out work should be marked UNLESS the candidate has replaced it with an alternative response.
- **Types of mark**
 - M marks: method marks
 - A marks: accuracy marks
 - B marks: unconditional accuracy marks (independent of M marks)
- **Abbreviations**
 - awrt – answers which round to.....
 - cao – correct answer only
 - ft – follow through
 - isw – ignore subsequent working

- SC - special case
- oe – or equivalent (and appropriate)
- dep – dependent
- indep – independent
- eeo – each error or omission

- **No working**

If no working is shown then correct answers normally score full marks

If no working is shown then incorrect (even though nearly correct) answers score no marks.

- **With working**

If there is a wrong answer indicated on the answer line always check the working in the body of the script (and on any diagrams), and award any marks appropriate from the mark scheme.

If it is clear from the working that the “correct” answer has been obtained from incorrect working, award 0 marks.

Any case of suspected misread loses A (and B) marks on that part, but can gain the M marks.

If working is crossed out and still legible, then it should be given any appropriate marks, as long as it has not been replaced by alternative work.

If there is a choice of methods shown, then no marks should be awarded, unless the answer on the answer line makes clear the method that has been used.

If there is no answer on the answer line then check the working for an obvious answer.

- **Ignoring subsequent work**

It is appropriate to ignore subsequent work when the additional work does not change the answer in a way that is inappropriate for the question: eg. Incorrect cancelling of a fraction that would otherwise be correct.

It is not appropriate to ignore subsequent work when the additional work essentially makes the answer incorrect eg algebra.

Transcription errors occur when candidates present a correct answer in working, and write it incorrectly on the answer line; mark the correct answer.

- **Parts of questions**

Unless allowed by the mark scheme, the marks allocated to one part of the question CANNOT be awarded in another.

Apart from Questions 9, 13(a), 20dii and 23 (where the mark scheme states otherwise) the correct answer, unless clearly obtained by an incorrect method, should be taken to imply a correct method.

Question Number	Working	Answer	Mark	Notes
1	12 : 8 oe or 8:12		2	M1
		1.5 oe		A1
				Total 2 marks
2		translation	2	B1 Also accept translated, translate etc
		$\begin{pmatrix} -2 \\ 1 \end{pmatrix}$		B1 Also accept 2 to the left and 1 up
				Total 2 marks
3	(i) $3 \times 2 + 4 \times 5 + 5 \times 14 + 6 \times 19 + 7 \times 10$ or $6 + 20 + 70 + 114 + 70$ or 280		4	M1 for sum of products condone one error
	"280" \div 50			M1 (dep) for division by 50
		5.6		A1 cao Also accept 6 if both method marks scored and 5 following 5.6
	(ii)	5		B1 ft from their (i)
				Total 4 marks

6	(a)(i)	$\angle ABC = 68^\circ$ or $\angle BCD = 112^\circ$		4	M1	May be stated or marked on diagram
			68		A1	cao
	(ii)	$360 - (67 + 112 + "68" + 74)$			M1	
			39		A1	ft from their (a)(i) Award 2 marks if the answer to (ii) is 107 - answer to (i)
	(b)	$(5 - 2) \times 180$ or 3×180 or $(2 \times 5 - 4) \times 90$ or 6×90 or $360 + 180$ or $(180 - 67) + (180 - 112) +$ $(180 - "68") + (180 - 74) +$ $(180 - "39")$ or $113 + 68 + 112 + 106 + 141$		2	M1	Condone 1 incorrect interior angle
			540		A1	Cao SC: Award B1 for answer of 108
Total 6 marks						
7	(i)		$-1 \leq x < 3$	4	B2	B1 for either $-1 \leq x$ or for $x < 3$ as a final answer
	(ii)		-1 0 1 2		B2	B1 for 4 correct and 1 wrong or for 3 correct and 0 wrong
Total 4 marks						
8		$5.2^2 + 3.8^2$ or $27.04 + 14.44$ or 41.48		3	M1	for squaring and adding
		$\sqrt{5.2^2 + 3.8^2}$			M1	(dep) for square root
			6.44		A1	for answer rounding to 6.44
Total 3 marks						

9	$3x + 32 = 87 - 2x$		4	M1 for $3x + 32 = 87 - 2x$
	$5x = 55$ or $5x - 55 = 0$ or $5x = 87 - 32$ or $3x + 2x = 55$			M2 for correct rearrangement with x terms on one side and numbers on the other AND correct collection of terms on at least one side or for correct collection to 2 terms M1 for correct rearrangement with y terms on one side and numbers on the other e.g $3x + 2x = 87 - 32$ or correct collection and simplification of either numbers or x terms eg $5x + 32 = 87$ or $5x = a$ or $bx = 55$
		11		A1 dependent on at least one M1
				Total 4 marks

13	(a)	$10x + 6y = 18$ $21x - 6y = 75$	$35x + 21y = 63$ $35x - 10y = 125$		4	M1	for coefficients of x or y the same or for correct rearrangement of one equation followed by substitution in the other eg $5x + 3\left(\frac{7x - 25}{2}\right) = 9$
		$x = 3$	$y = -2$			A1	
		eg $5 \times 3 + 3y = 9$				M1	(dep on first M1) for substituting for the other variable
				3	-2	A1	cao dep Award full marks for correct values if at least first M1 scored
	(b)			3	-2	1	B1 ft from (a)
							Total 5 marks

14		$3380 \div 1.04$ or 3250 or 1.04^2 or 1.0816			4	M1	or M2 for $3380 \div 1.04^2$ oe
		$3250 \div 1.04$				M1	
		3125				A1	
				255		A1	cao
							Total 4 marks

15	(a)			67	1	B1	cao
	(b)(i)			113	2	B1	cao
	(ii)	eg sum of opposite angles of a cyclic quadrilateral = 180°				B1	Accept reasons which include 'opposite' and 'cyclic', ' 180° (or supplementary)' and nothing incorrect
							Total 3 marks

16	$6.7^2 + 5.2^2 - 2 \times 6.7 \times 5.2 \cos 117^\circ$ or $44.89 + 27.04 - (-31.63\dots)$		3	M1
	103.56...			A1 for awrt 104
		10.2		A1 for awrt 10.2 (10.1766...)
				Total 3 marks

17 (a)	$y = kx^3$ or $ky = x^3$		3	M1 for $y = kx^3$ but not for $y = x^3$
	$250 = 1000k$			M1 for $250 = 1000k$ Also award for $250 = k \times 10^3$
		$y = \frac{1}{4}x^3$ oe		A1 for $y = \frac{1}{4}x^3$ oe Award 3 marks if answer is $y = kx^3$ and k is evaluated as $\frac{1}{4}$ oe in part (a) or part (b)
(b)	$54 = \frac{1}{4}x^3$		2	M1 dep on at least first M1 in part (a)
		6		A1 ft from $x^3 = 54 \div \frac{1}{4}$ oe
				Total 5 marks

18	(a)	$\frac{6}{10} + \frac{3}{10}$		2	M1	
					A1	$\frac{9}{10}$ oe
	(b)	$\frac{6}{10} \times \frac{5}{9}$ oe and no other terms		2	M1	
					A1	$\frac{30}{90}$ oe inc $\frac{1}{3}$
	(c)	$\frac{6}{10} \times \frac{3}{9}$ oe or for $\frac{3}{10} \times \frac{1}{9}$ oe or for $\frac{7}{10} \times \frac{3}{9}$		3	M1	SC M1 for $\frac{6}{10} \times \frac{3}{10}$ oe or $\frac{3}{10} \times \frac{1}{10}$ oe
		$\frac{6}{10} \times \frac{3}{9} + \frac{3}{10} \times \frac{6}{9} + \frac{3}{10} \times \frac{1}{9} + \frac{1}{10} \times \frac{3}{9}$ oe or for $\frac{7}{10} \times \frac{3}{9} + \frac{3}{10} \times \frac{7}{9}$ oe			M1	M1 for $\frac{6}{10} \times \frac{3}{10} + \frac{3}{10} \times \frac{6}{10} + \frac{3}{10} \times \frac{1}{10} + \frac{1}{10} \times \frac{3}{10}$ oe
					A1	$\frac{42}{90}$ oe inc $\frac{7}{15}$
					A1	Sample space method – award 3 marks for a correct answer; otherwise no marks
Total 7 marks						

19		$2 \times \pi \times 3.4 \times 8.3$ or 56.44π or $177.3...$		4	M1	
		$\pi \times 3.4^2$ or 11.56π or $36.31...$			M1	
		$2 \times \pi \times 3.4^2$ or 23.12π or $72.63..$			M1	
					A1	286 for awrt 286
Total 4 marks						

20	(a)		4.25 16.5	1	B1	for both values correct
	(b)		Points	2	B1	Allow $\pm \frac{1}{2}$ sq ft from their table
			Curve		B1	ft from their points if at least 6 points plotted correctly
	(c)		0.1 to 0.2 and 3.7	2	B2	B1 for each correct value $\pm \frac{1}{2}$ sq ft from their graph if at least 1 mark scored in (b) tol
	(d)(i)		3	3	B1	cao
	(ii)	Draw $y = 3x$			M1	from $x = 1$ to at least $x = 3$
			approx 2.7		A1	ft from their graph if at least 1 mark scored in (b) and dep on M1
						Total 8 marks

21		3	M2	for complete, correct Venn Diagram (outline, labels and numbers) (accept blank instead of 0)
		22	A1	cao
				Total 3 marks

22	$\frac{42}{6}$ or 7		5	B1
	$\frac{1}{2} \times 7^2 \times \sin 60^\circ$ or 21.2(1... Or $7 \times \sqrt{14^2 - 7^2}$ and $\frac{1}{2} \times 7 \times \sqrt{14^2 - 7^2}$			M2 Alternative methods M1 for $\sqrt{7^2 - 3.5^2}$ or $7 \sin 60^\circ$ or 6.062... M1 (dep) for $\frac{1}{2} \times 7 \times "6.062..."$ or 21.21... Or M1 for $\sqrt{14^2 - 7^2}$ and 3.5 M1 for $7 \times "12.12"$ and $\frac{1}{2} \times 3.5 \times "12.12..."$ Or Other equivalent methods (see end of Mark Scheme.
	"21.21..." \times 6 or $7 \times "12.12" + 2 \times "21.21"$			M1 dep on preceding 3 marks summing all the areas to make up the hexagon
		127		A1 for answer rounding to 127
				Total 5 marks

ALTERNATIVES FOR QUESTION 22

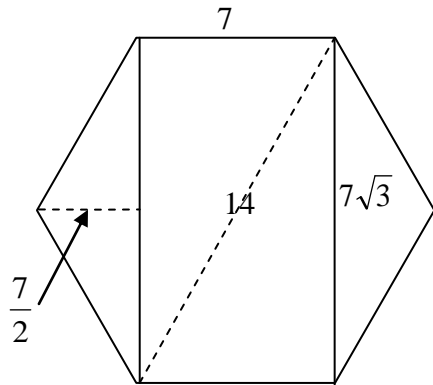

$$7 \times 7\sqrt{3} + 2 \times \frac{1}{2} \times \frac{7}{2} \times 7\sqrt{3}$$

$$7 \times 12.12... + 3.5 \times 12.12$$

$$84.87... + 42.43....$$

$$\frac{147}{2} \sqrt{3}$$

$$7 \times 7\sqrt{3} + 2 \times \frac{1}{2} \times 7 \times 7 \times \sin 60$$

$$7 \times 12.12... + 3.5 \times 12.12$$

$$84.87... + 42.43....$$

$$\frac{147}{2} \sqrt{3}$$

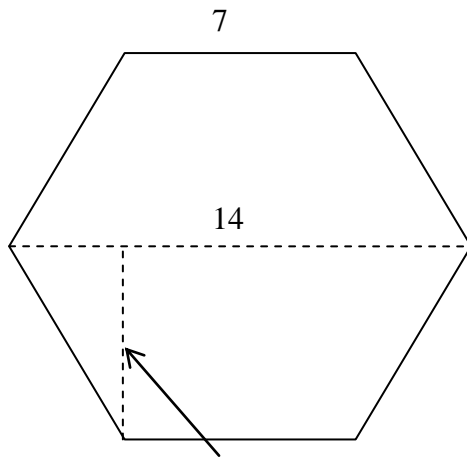

$$7 \sin 60 = \frac{7\sqrt{3}}{2} = 6.062...$$

$$\frac{1}{2} \times 14 \times \frac{7\sqrt{3}}{2} = \frac{21}{2} \times \frac{7\sqrt{3}}{2}$$

$$= 10.5 \times 6.06... = 63.65....$$

$$\frac{1}{2} \times 14 \times \sqrt{7^2 - 3.5^2} = \frac{21}{2} \times \frac{7\sqrt{3}}{2}$$

$$= 10.5 \times 6.06... = 63.65....$$

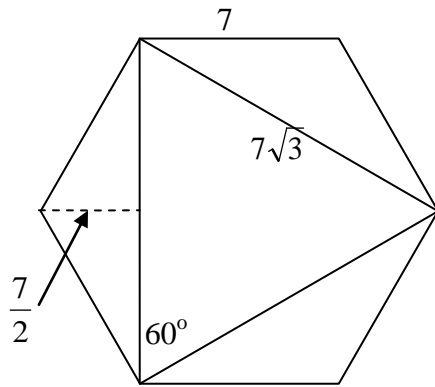

$$\frac{1}{2} \times 7\sqrt{3} \times 7\sqrt{3} \times \sin 60 + 3 \times \frac{1}{2} \times \frac{7}{2} \times 7\sqrt{3}$$

$$63.65.. + 5.25 \times 12.12.....$$

$$63.65... + 63.65.....$$

$$127.3...$$

Further copies of this publication are available from
Edexcel Publications, Adamsway, Mansfield, Notts, NG18 4FN

Telephone 01623 467467
Fax 01623 450481
Email publication.orders@edexcel.com
Order Code UG036369 Summer 2013

For more information on Edexcel qualifications, please visit our website
www.edexcel.com

Pearson Education Limited. Registered company number 872828
with its registered office at Edinburgh Gate, Harlow, Essex CM20 2JE

Ofqual
.....



Llywodraeth Cynulliad Cymru
Welsh Assembly Government

